

Medical Grade Power Supply

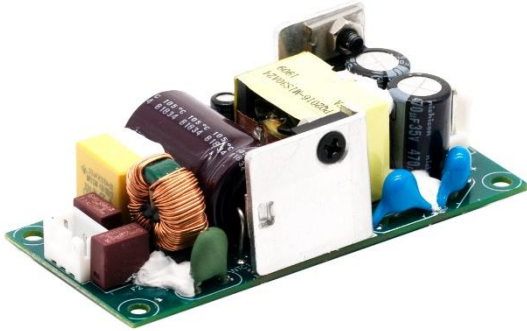

MIS30

High Efficiency Compact Power Supply



Highlights:

- For Industrial and Medical Application
- High Power Density
- 30W Convection Cooling
- Class II
- Up to 89% Efficiency
- -10°C to +70°C Operation, up to +50°C without derating
- Low Standby < 0.15W
- Light Weight
- >500 kHour MTBF
- 2MOPP Isolation
- Suitable for BF Type Design
- 5000 meter operation altitude

Key Specification

Model	MIS30B05	MIS30B09	MIS30B12	MIS30B15	MIS30B18	MIS30B24	MIS30B36	MIS30B48
Output Voltage	5V	9V	12V	15V	18V	24V	36V	48V
Rated Output Current	4A	3A	2.5A	2.0A	1.66A	1.25A	0.83A	0.63A
Rated Output Power	20W	27W	30W					
Warranty	3 Years							
Dimension	1.36"x3.07"x0.9" or 34.54mm x78mm x 22.86mm							
EMC	IEC60601-1-2 4 th Edition							
Safety Standard	IEC60601-1 3 rd +A1 Edition CB Report							

Model Name

MIS

30

B

24

Series Name

Rated Power

CLASS

Output Voltage

Control Code

B: CLASS II

AA: Standard Model

SPECIFICATIONS

All specifications are for rated input/output and 25°C unless otherwise specified

INPUT CHARACTERISTICS

Function	Minimum	Typical	Maximum	Condition
Rated Input Voltage	100 VAC		240 VAC	
Input Voltage Range	85 VAC		264 VAC	Output Power Derating from 100% load at 90VAC to 85% load at 85VAC. See Fig.1
Input Frequency	47 Hz	50/60 Hz	63 Hz	
Input Current			1 A @ 100VAC 0.5A @ 230VAC	
Efficiency		89%		24V Model, Rated Input and Output
Inrush Current			40 A	240VAC Input, Cold Start

OUTPUT CHARACTERISTICS

Function	Minimum	Typical	Maximum	Condition
Peak Power			120% Load	20ms duration
Output Voltage Total Regulation			±3%	Including initial tolerance, line regulation and load regulation
Output Ripple & Noise			1%	Peak to peak value
Turn on delay Time			2s	
Rise Time			100ms	
Holdup Time	12ms			115VAC 60Hz Input

PROTECTION CHARACTERISTICS

Function	Minimum	Typical	Maximum	Condition
Over Current Protection (OCP)	120% Rated Current		160% Rated Current	Auto-restart after fault condition is removed
Short Circuit Protection (SCP)				Auto-restart after fault condition is removed
Over Voltage Protection (OVP)			130% Rated Output Voltage	Latch off
Over Temperature Protection (OTP)				Latch off

ENVIROMENTAL

Function	Minimum	Typical	Maximum	Condition
No Load Power Consumption			0.15 W	115VAC/60Hz and 230VAC/50Hz Input 15V & below models only
Operation Ambient Temperature	-10 °C		70 °C	Output Power Derating from 100% load at 50°C to 50% load at 70°C. See Fig.2
Cooling				Convection Cooled
Operation Humidity	5% RH		95% RH	Non-condensing
Storage Ambient Temperature	-40 °C		80 °C	
Storage Humidity	5% RH		95% RH	Non-condensing
Operating Altitude			5000 m	Or 16,400 feet
Shock (Non-Operation)			50 g	11ms, 3 shocks for each direction
Vibration (Operation)			2 g _{RMS}	5-500Hz, 15 Minutes for each three axis
Weight			70 gram	

EMC

Item	Description
Conducted Emissions	EN55011/EN55022, FCC TITLE 47: Class B
Radiated Emissions	EN55011/EN55022, FCC TITLE 47: Class B
Harmonic Current Emissions	IEC61000-3-2, Class D
Voltage Flicker	IEC61000-3-3
Electrostatic Discharge	IEC61000-4-2, Level 4, Criteria A. Air Discharge 15kV, Contact Discharge 8kV
Radiated, radio-frequency, electromagnetic field immunity	IEC61000-4-3, Criterion A 80MHz-2700MHz, 10V/m 80%AM 1kHz modulation IEC60601-1-2:2012 Table 9
Electrical Fast Transient	IEC61000-4-4, Criterion A. 2kV On Power Port, 100kHz
Surge	IEC61000-4-5, Level 3 Criteria A. Common mode 2kV, Differential Mode 1kV
Conducted Immunity	IEC61000-4-6, Level 2 Criteria A. 150kHz-80MHz, 3Vrms, 6Vrms at ISM Band sand Amateur radio bands
Power Frequency Magnetic Fields	IEC61000-4-8, Criteria A. 30A/m
Voltage Dips	IEC61000-4-11 Criteria A: 30% 10ms, Criteria B: 60% 100ms, 100% 5000ms
	IEC60601-1-2 Criteria A: 100% 10ms at step 45° (load derating required for 100VAC) Criteria B: 30% 500ms, 100% 20ms, 100% 5000ms

SAFETY & DIRECTIVES

Item	Description
Safety Standards	IEC62368-1 CB Report, TUV62368-1, CSA/UL62368-1 (Compliance Only) IEC60601-1 3 rd edition+A1 TUV EN60601-1:2006, UL60601-1+CAN/CSA C22.2 NO.60601-1
Directives	MDD Directive 93/42/EEC RoHS Directive 2011/65/EU Compliant
Dielectric Voltage	Primary to Secondary (2XMOPP): 4kVAC
Touch Current @264VAC, 60Hz	<100uA @ Normal Condition <300uA @ Single Fault Condition

RELIABILITY

Function	Minimum	Typical	Maximum	Condition
MTBF	500 kHours			According to MIL-HDBK-217F. 25°C

DERATING CURVE

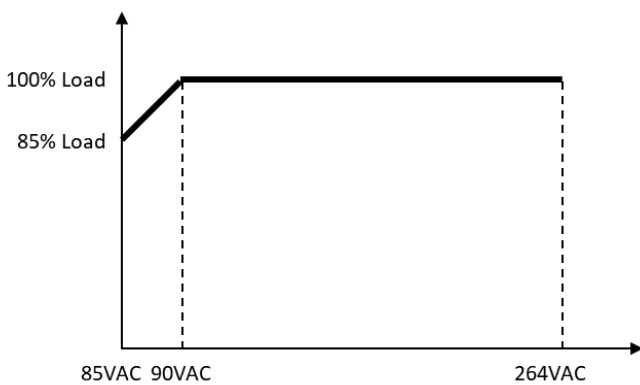

Figure 1

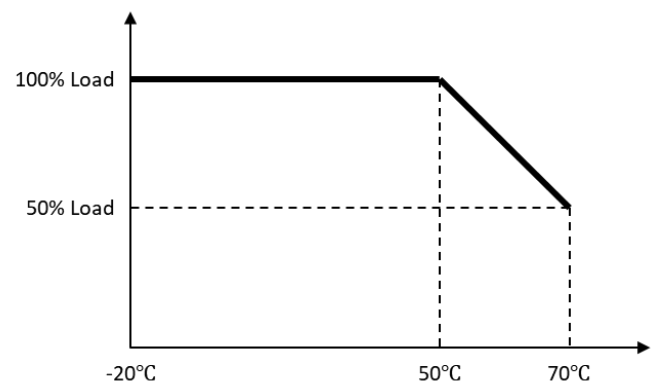
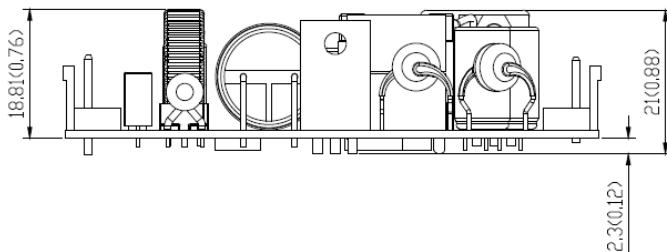
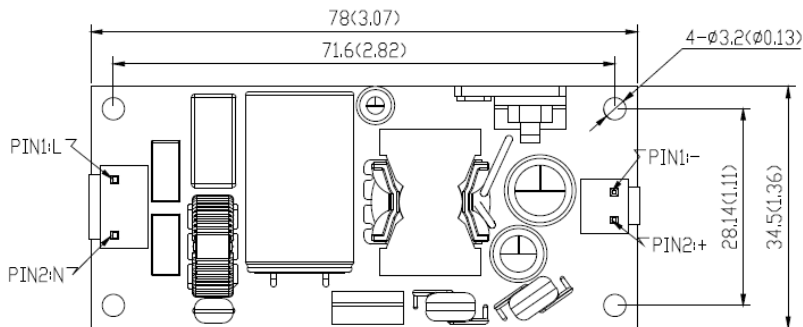

Figure 2

MECHANICAL DETAIL

Open Frame Chassis Mount



Dimensions in mm(inches)
 Tolerances:
 x.x = ± 0.5 (x.x = ± 0.02)

Note: All mounting hole related hardware must be non-conductive.

MATING CONNECTOR

Input Connector: JST VHR-3N

Crimp Terminals: SVH-21T-P1.1

Output Connector: JST VHR-2N

Crimp Terminals: SVH-21T-P1.1

CONTACTS & OTHER INFORMATION

For more information, please visit www.appliedpsu.com

For sales inquiries, please send an email to sales@appliedpsu.com

User manual and other document available at www.appliedpsu.com/support